

Description

The EFRBC Series are designed to securely attach a length of steel angle to a conventional hanging threaded rod.

The EFRBC hanging rod stiffener clamps consist of a one piece bright zinc plated 0.180" thick formed metal stamping, complete with attachment bolt and locknut.

The EFRBC rod stiffener clamps are manufactured in two (2) models.

EFRBC-B clamp is designed to accept angles ranging in size from 1" x 1" x 1/8" thick, up to 1-1/2" x 1-1/2" x 1/4" thick, and rod sizes ranging from 3/8" up to 1-1/8" in diameter.

EFRBC-C clamp is designed to accept angles ranging in size from 1-3/4" x 1-3/4" x 3/16" thick, up to 2-1/2" x 2-1/2" x 1/4" thick, and rod sizes ranging from 3/8" up to 1-1/2" in diameter.



Applications

The EFRBC hanging rod stiffener clamps are required in order to brace threaded rod when this rod is used to suspend piping, ductwork, and hanging equipment in a seismic zone. Suspended threaded rod, when subjected to seismic forces, can buckle and fail when these forces put the rod in compression. Auxiliary steel stiffening angles are therefore used to brace and to stiffen the threaded rod. EFRBC Model hanging rod stiffener clamps are designed to easily and securely attach these bracing angles to the threaded rod, using common hand tools.

The design of the EFRBC clamp allows the installation of the angle bracing without the requirement to disassemble the hanging rod. This feature makes the EFRBC clamp ideal for use in retrofit installations.

Seismic building codes should be referenced in order to determine the size and thickness of the bracing angle, as well as the quantity of attachment clamps required.

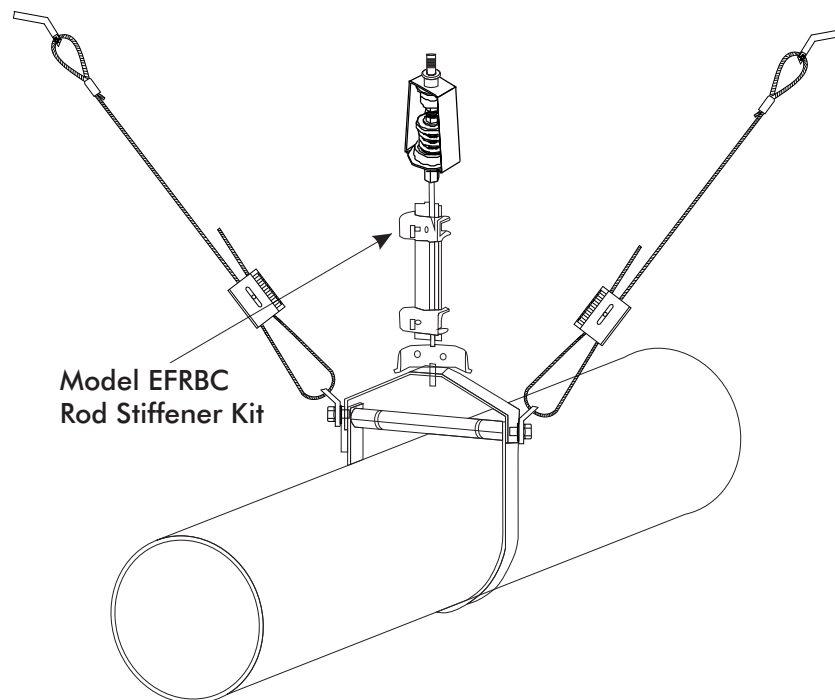

Specifications

Seismic rod stiffener angle bracing shall be securely attached to hanging thread rod by a series of attachment clamps. Attachment clamps shall be manufactured from a one piece metal stamping, and shall include all required attachment hardware and locking nuts. Attachment clamps shall be bright zinc plated for corrosion protection. Attachment clamps shall be capable of installation or removal without the need to disassemble the suspended equipment.

Attachment clamps made from aluminum, steel, or iron castings can be brittle and shall not be acceptable for use in seismic applications.

Seismic rod stiffener angle attachment clamps shall be capable of attaching angles ranging in size from 1" x 1" x 1/2" thick up to 2-1/2" x 1/4" thick, to threaded rod ranging in size from 3/8" to 1-1/2" diameter.

Seismic rod stiffener angle attachment clamps shall include locking hardware to prevent any potential for loosening due to (piping) (ductwork) (suspended equipment) operational vibration. Seismic clamps shall be capable of installation using common hand tools, with no specialized or unique installation tools required.

Seismic rod stiffener angle attachment clamps shall be Model EFRBC as manufactured by Easyflex.

Installation Instruction

Check project drawing and specifications for quantity, size, and location of angle bracing and EFRBC clamps.

Place stiffening angle along side threaded rod, centering along the length of the rod.

Loosen the attachment bolt on the EFRBC clamps and slide the clamp over the angle brace, positioning the end of the attachment bolt against the threaded rod as shown in the EFRBC submittal drawings.

Turn the EFRBC attachment bolt down onto the threaded rod, tightening the bolt finger tight plus one (1) turn.

Turn the locking nut on the EFRBC adjustment bolt tight against the clamp body to prevent any potential for the adjustment bolt to become loose.

	A		B		C		D	E	F
Model	in.	mm	in.	mm	in.	mm	* Hex HD. Bolt	* Hex Jam Nut	Max Rod Size
EFRBC-B	1.38	35	3.13	79	2.00	51	3/8-16 UNC X 2.0*	3/8-16 UNC*	1-1/8 (28)
EFRBC-C	1.38	35	4.44	113	2.13	54	3/8-16 UNC X 2.0*	3/8-16 UNC*	1-1/8 (38)

Model	AISC Standard	Metric
EFRBC-B	1 x 1 x 1/8	25 x 25 x 3
EFRBC-B	1-1/4 x 1-1/4 x 1/4	30 x 30 x 5
EFRBC-B	1-1/2 x 1-1/2 x 1/4	40 x 40 x 6
EFRBC-C	1-3/4 x 1-3/4 x 1/4	45 x 45 x 6
EFRBC-C	2 x 2 x 1/4	50 x 50 x 6
EFRBC-C	2 x 2 x 3/8	50 x 50 x 8
EFRBC-C	2-1/2 x 2-1/2 x 1/4	60 x 60 x 6

