

## AN INTRODUCTION TO EASYFLEX SEISMIC BRACING SYSTEMS

Easyflex Seismic Bracing Systems are designed and engineered to brace and secure non-structural equipment and services within a building or structure to minimise earthquake damage to suspended services.

Easyflex Seismic Bracing Systems are ideal for use on non-structural equipment and services requiring seismic support, such as essential facilities that are required for emergency operations in the aftermath of an earthquake.

### Advantages:

- Complete pre-engineered systems
- Easyflex offer a complete system
- No additional swaging required on site
- Up to 10 times faster to install
- No tools required

## THE DIFFERENCE BETWEEN STRUCTURAL AND NON-STRUCTURAL COMPONENTS

Structural components are made up of roofs, floors, beams, columns, foundations, walls, whereas non-structural components are architectural elements, mechanical and electrical equipment and supplies and other building furniture.

Non-Structural components are very important in the correct functioning of a building in the aftermath of an earthquake. Bracing these systems ensures higher safety levels for the occupants of the building.

## EASYFLEX SEISMIC BRACING SYSTEMS - KITS AND IDENTIFICATION

The Easyflex Seismic Bracing Systems are available in kit form, comprising:

- Pre-determined length of wire, with a seismic bracket end
- Seismic rod bracket
- Easyflex



Easyflex Seismic Systems are colour coded so as to ensure easy recognition of wire diameter in buildings:

- Red = 2mm cable
- Blue = 3mm cable
- Green / Yellow = 4mm cable



## EASYFLEX SEISMIC BRACING SYSTEMS - FAZ II CEILING ANCHOR

### INSTALLATION OF THE FAZ II

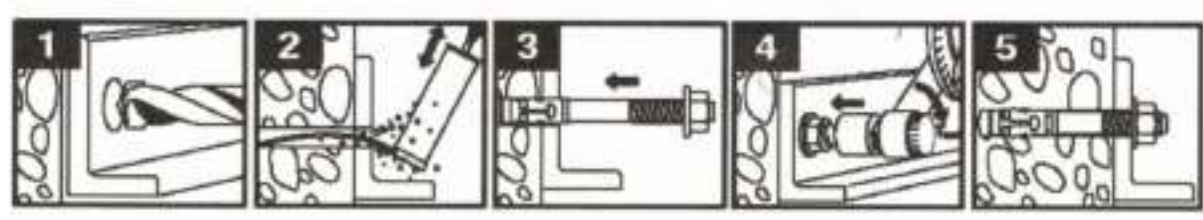

- Step 1:** Drill the hole by using the correct metric bit diameter. Drill hole to minimum required hole depth or deeper
- Step 2:** Remove drilling debris with a blowout bulb or with compressed air
- Step 3:** Using a hammer, tap the anchor through the part being fastened into the drilled hole until the washer is in contact with the fastened part. Make sure that the minimum required effective anchorage depth is kept and that the maximum thickness of fixture is not exceeded
- Step 4:** Using a torque wrench, apply the specified installation torque

### FAZ II INSTALLED

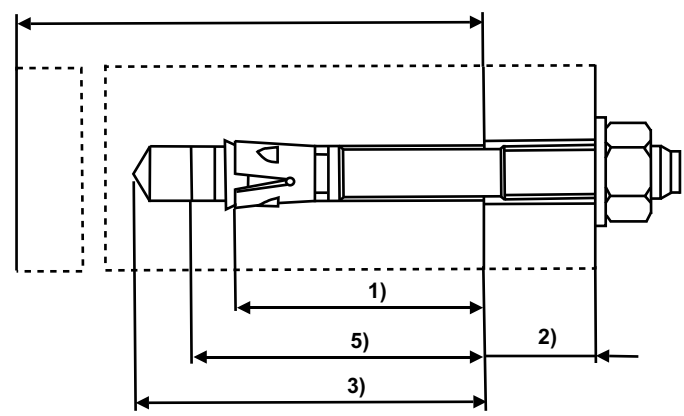

- 1) Effective anchorage depth
- 2) Thickness of fixture
- 3) Drill hole depth
- 4) Min thickness of concrete member
- 5) Distance between the embedded end of the anchor and the concrete surface

## EASYFLEX SEISMIC BRACING SYSTEMS - BRACING METHODS

There are two different types of seismic bracing methods:

- Transverse Bracing
- Longitudinal Bracing



### Transverse Bracing

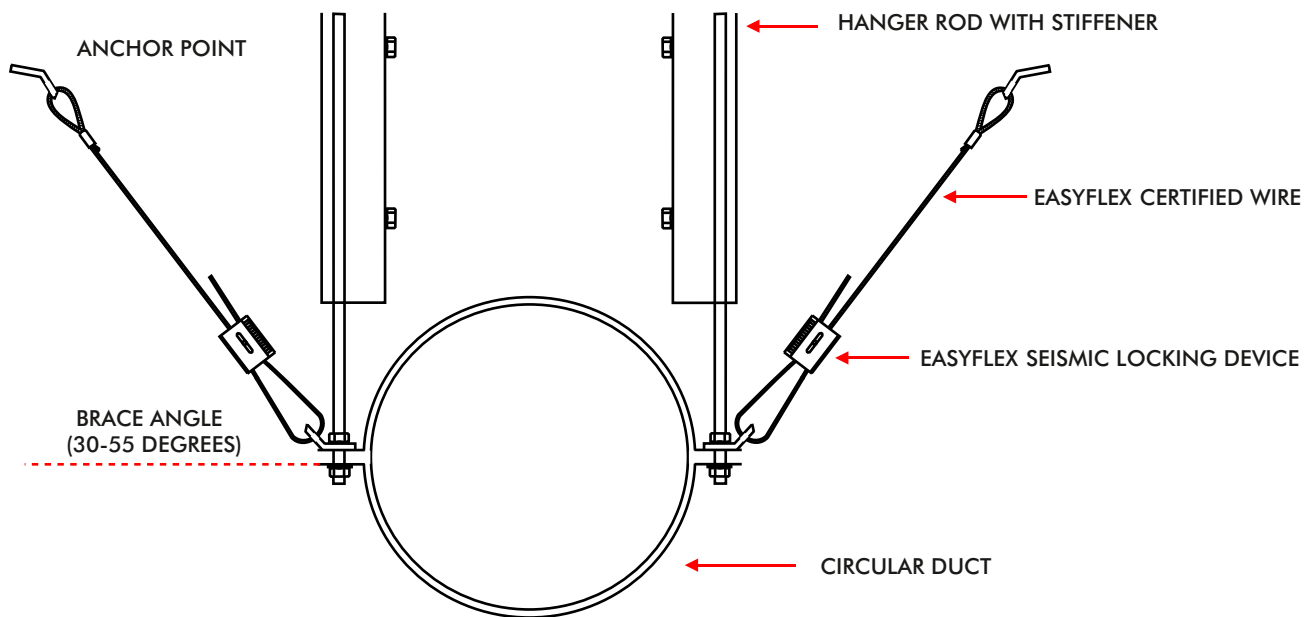

Transverse bracing restrains seismic forces perpendicular to a run of braced piping or ductwork. During an earthquake, a vertical force may be generated, therefore rod stiffeners are required so as to ensure the rod does not buckle.

### MAXIMUM BRACE SPACING LIMITS FOR TRANSVERSE BRACING:

MATERIAL TYPE	PIPING DIAMETER	SPACING
Ductile	Minimum 63mm	12 Metres
Ductile	Maximum 63mm	9 Metres
Non-Ductile		6 Metres

## Longitudinal Bracing

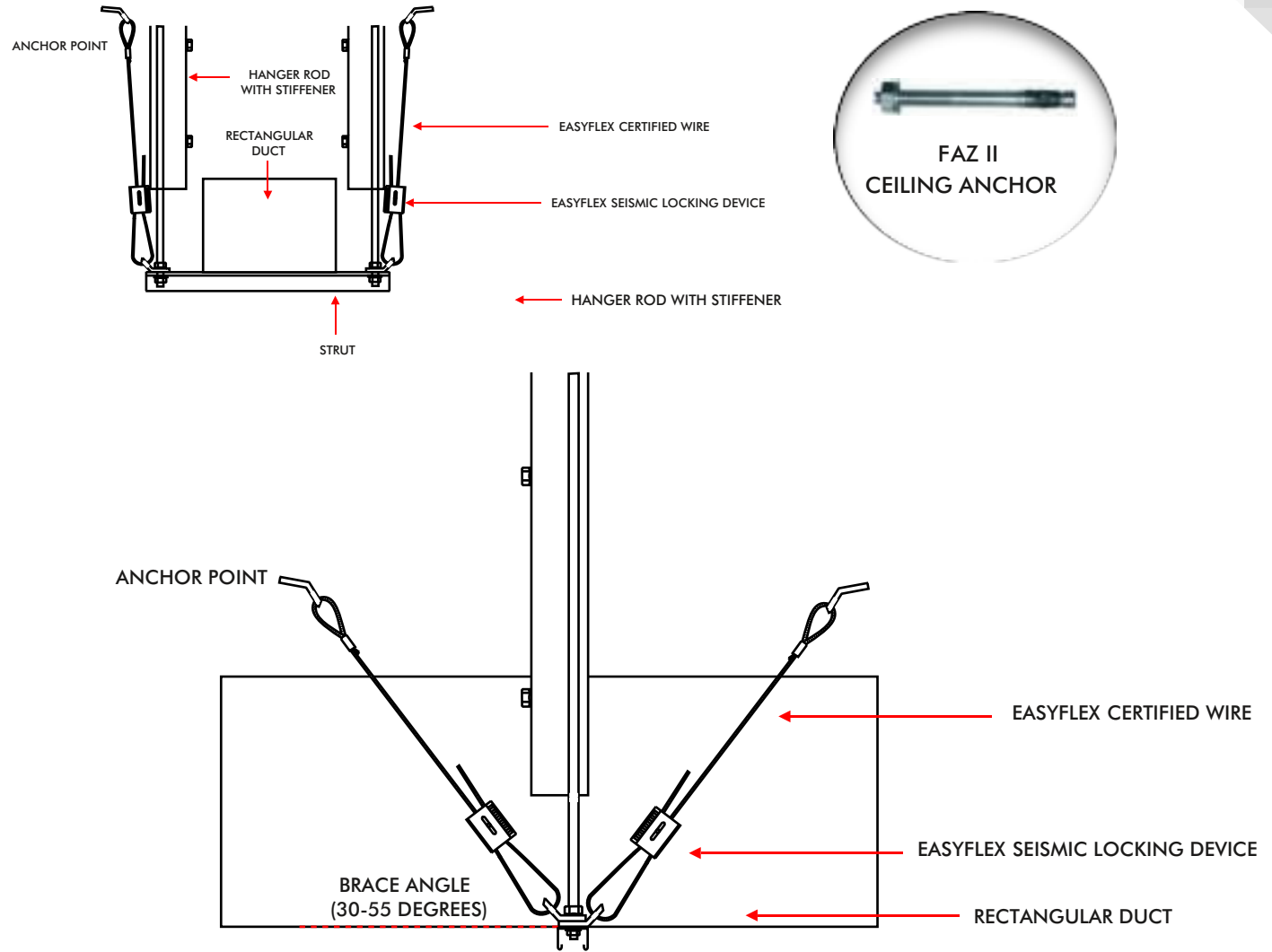

Longitudinal bracing restrains seismic forces parallel to a run of braced piping or ductwork. During an earthquake, a vertical force may be generated, therefore rod stiffeners are required so as to ensure the rod does not buckle.

### MAXIMUM BRACE SPACING LIMITS FOR TRANSVERSE BRACING:

MATERIAL TYPE	PIPING DIAMETER	SPACING
Ductile	Minimum 63mm	12 Metres
Ductile	Maximum 63mm	9 Metres
Non-Ductile		6 Metres

## EASYFLEX SEISMIC BRACING SYSTEMS - PRODUCT CODES

PRODUCT CODE	DESCRIPTION	SAFE WORKING LOAD	
SB/PLEK2R	Seismic Restraint System R 2 Metres	193lbs	2:1 SF
SB/PLEK3R	Seismic Restraint System R 3 Metres	193lbs	2:1 SF
SB/PLEK5R	Seismic Restraint System R 5 Metres	193lbs	2:1 SF
SB/PLEK2B	Seismic Restraint System B 2 Metres	462lbs	2:1 SF
SB/PLEK3B	Seismic Restraint System B 3 Metres	462lbs	2:1 SF
SB/PLEK5B	Seismic Restraint System B 5 Metres	462lbs	2:1 SF
SB/PLEK2GY	Seismic Restraint System GY 2 Metres	886lbs	2:1 SF
SB/PLEK3GY	Seismic Restraint System GY 3 Metres	886lbs	2:1 SF
SB/PLEK5GY	Seismic Restraint System GY 5 Metres	886lbs	2:1 SF
SB/PLEK2BK	Seismic Restraint System BK 2 Metres	1848lbs	2:1 SF
SB/PLEK3BK	Seismic Restraint System BK 3 Metres	1848lbs	2:1 SF
SB/PLEK5BK	Seismic Restraint System BK 5 Metres	1848lbs	2:1 SF
SB/R	45 Degree Bracing Bracket for Rod Suspensions	N/A	
FAZ II M10	M10 Seismic Strength Anchor	528lbs	5:1 SF

## EASYFLEX SEISMIC BRACING SYSTEMS - CLIP INSTALLATION

- Pass the wire through the easyflex
- Loop the wire through the fixing bracket
- Pass the wire back through the easyflex allowing 15cm of wire protruding
- Apply tension

Please refer to Appendix 4 for installation of particular systems

## TYPICAL INSTALLATION IMAGES - TRANSVERSE BRACING



## TYPICAL INSTALLATION IMAGES - LONGITUDINAL BRACING

